



# Model 1100 & 1500 Sliding Doors

Service & Installation



November, 2012

99-20361-I001

**Table of Contents**

I. Models 1100/1500 Door & Frame Parts Placement..... 3

II. Frame Installation..... 4

III. Door Installation ..... 5

IV. Door Removal ..... 7

V. Ordering Replacement Doors..... 10

VI. Ordering Replacement Frames ..... 10

VII. Door Plastic (Cover) Replacement..... 11

VIII. Door Handle Replacement..... 11

IX. Models 1100/1500 Cross-Section Construction & Dimensions ..... 12

X. Roller Cage Replacement ..... 12

XI. Door Lock Installation..... 14

XII. Door Heater Replacement and/or Door Plug Replacement..... 14

XIII. Frame Heater Replacement ..... 15

XIV. Frame Gasket Replacement (Prior to 1985)..... 15

XV. Frame Gasket Replacement (1985 to Present)..... 16

XVI. Frame Female Plug Replacement..... 16

XVII. Pre-Wired Ballast Replacement ..... 17

XVIII. Bulb Replacement..... 18

XIX. Lamp Socket Replacement ..... 18

XX. Models 1100 & 1500 (120-Volt) Ballast Wiring Diagram ..... 19

XXI. Shelving Installation (Prior to 1984) ..... 20

XXII. Four-Post Stabilizer Bar Installation ..... 22

XXIII. Four-Post Shelf System Installation ..... 23

XXIV. Plastic Tag Molding Installation..... 25

XXV. Model 1100 Shelf Assembly..... 27

XXVI. Glass Replacement (Reglazing)..... 27

XXVII. Humastat Installation..... 30

XXVIII. Electrical Information for Model 1100..... 34

XXIX. Electrical Information for Model 1500..... 35

XXX. Heat Load in BTU/Hr for Model 1100 ..... 36

XXXI. Heat Load in BTU/Hr for Model 1500 ..... 36

XXXII. Dew Point Chart ..... 37

XXXIII. Troubleshooting ..... 37

XXXIV. Safety Precautions ..... 39

XXXV. Tips..... 39

I. Models 1100/1500 Door & Frame Parts Placement

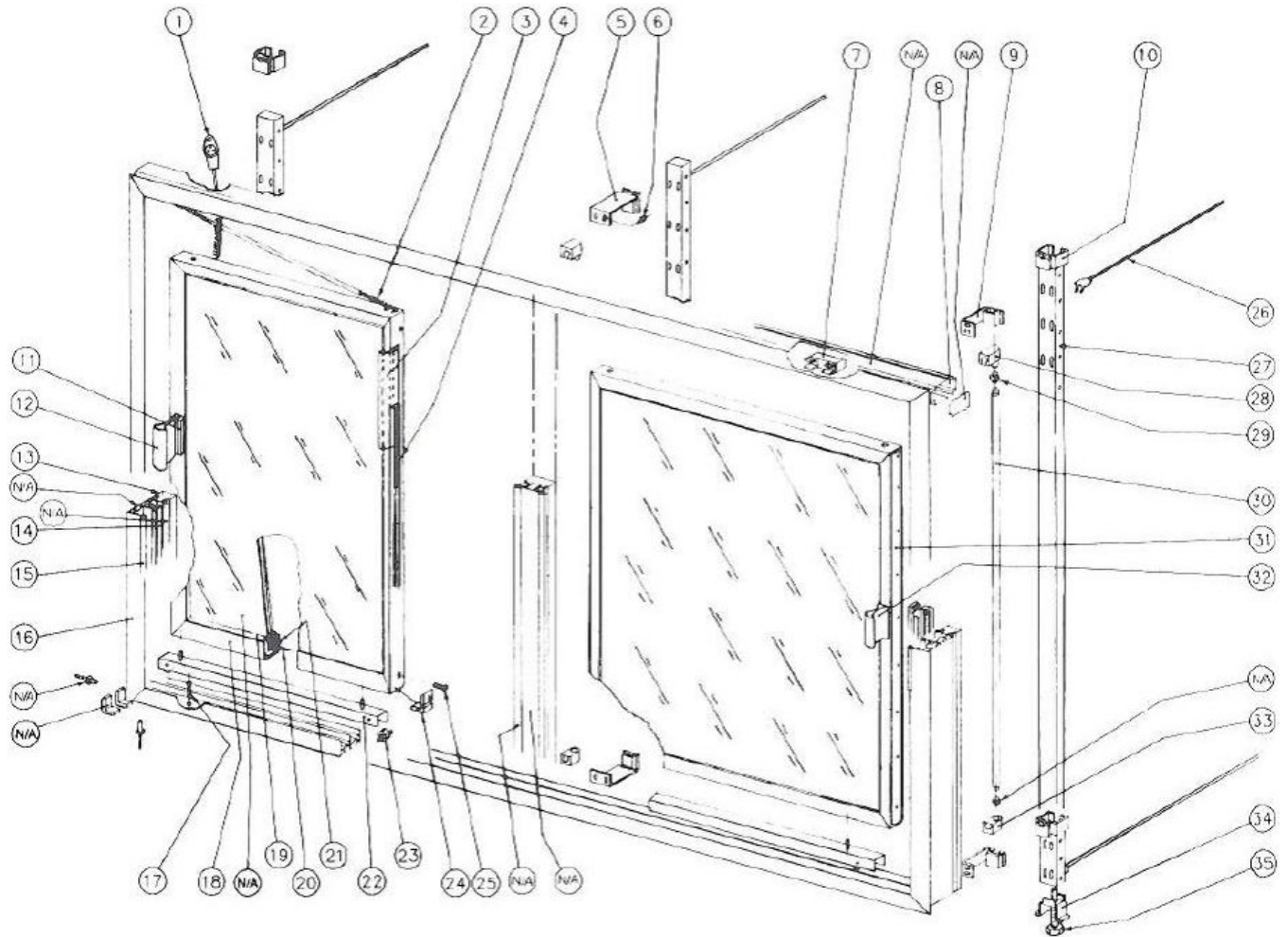

Description	Description	Description	Description
1. Plug	10. Retainer	19. Glazing Channel	28. Lamp Socket
2. Spring	11. Bumper	20. Door Heater	29. End Cap
3. Flap	12. Handle	21. Plastic	30. Bulb
4. Retainer	13. End Light	22. Roller Cage	31. Stainless
5. Bracket	14. Gasket	23. Roller	32. Handle
6. Screw	15. Plastic Runner	24. Corner Piece	33. Lamp Socket
7. Ballast	16. N/A	25. Cover Screw	34. Bracket
8. Cover	17. Installation Screw	26. Post Stabilizer	35. Bolt
9. End Bracket	18. Door Rail	27. Shelf Post	

**II. Frame Installation**

1. Read instructions completely before installing frames.
2. Openings must conform to net openings listed in Price Book or other.
3. Check size of finished frame to net opening.
4. **Do not force frame into tight opening.**
5. Check net opening for plumb and square, as shown below. Sill must be level left to right and front to back.

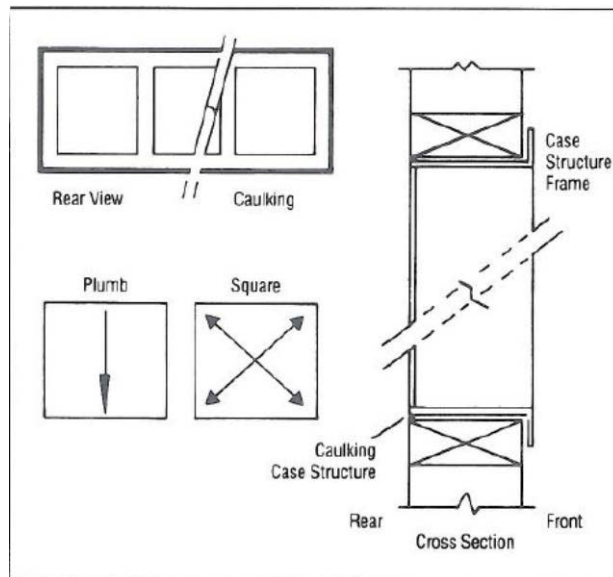

*Frame Installation*

- a. Jambs, header and sill should be wood for secure installation.
  - b. Anthony door frame needs a sill of at least 1-1/2"
6. Set frame in case opening. For safety, partially install wood screws into top of frame. **Do not tighten.**

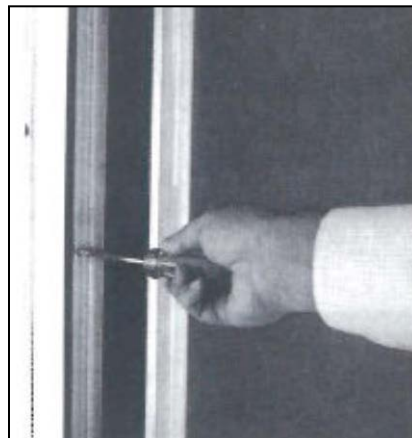

7. Check frame for square, as shown in *Frame Installation*. Shim as necessary. Ensure that shims are placed as close to installation holes as possible. When shimming is necessary, shim top and bottom and/or left and right end of frame to maintain square in net opening.
8. From inside of case, **caulk all four (4) sides of frame**, between frame and case opening, as shown in *Frame Installation*.
9. Starting with the frame sill, install mounting screws and tighten. Then do sides and top. **Do not over-tighten top screws as this will bow frame.**
10. From inside the case, re-check caulking and re-caulk if necessary.

### III. Door Installation

1. Remove roller cage from bottom of door.

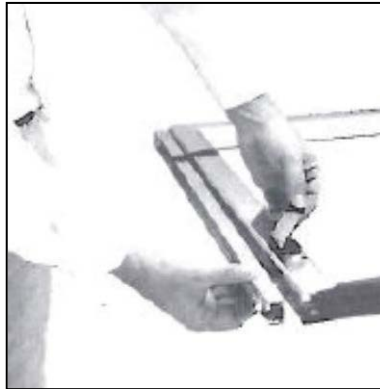

2. Install roller cage in rear track.

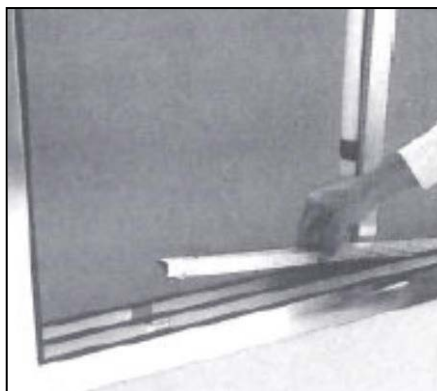

3. If optional spring closer is included, start with the rear door (door with back flap). Attach the spring closer to the hook on top of door.

**Note: Doors wider than 30" are not designed for a self-closing spring.**

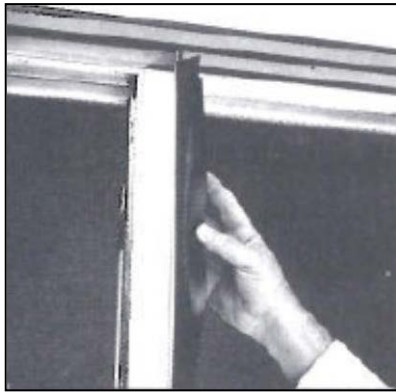

4. With spring attached, lift door into top rear track.



5. Position pre-punched holes in the base of door over threaded pins on the roller cage. Drop door into position.

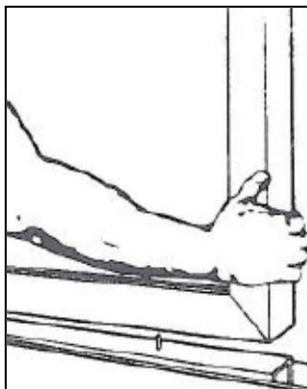

6. ***Note that Roller cage does not screw into bottom of door.***

7. If doors or glass are heated, install door plug into socket on top back of raceway. Repeat above instructions to install front door.

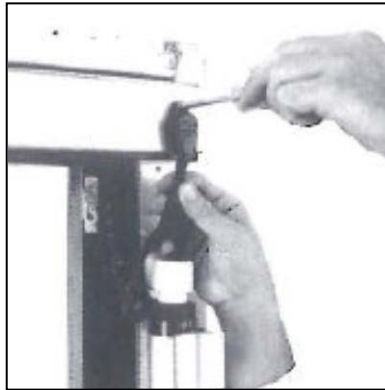

**Note:** Heater coil cords will always be located on left and right handle side of doors. On a three-door slider, there is no heater cord on center door.

8. Clean-out holes have been provided in bottom track of frame track for easy cleaning.

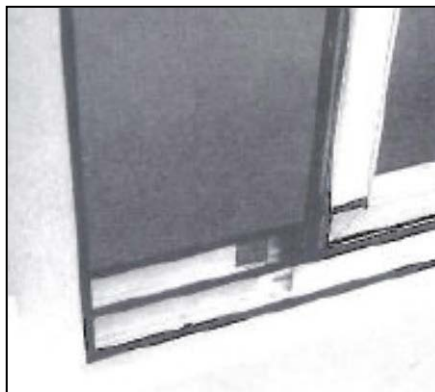

9. ***Do not use power tools for installation or removal.***
10. As of August 1993, frames include a stainless steel replaceable bottom track. To replace, simply remove back of two-way tape and lay track over existing track. Press down to install.

#### **IV. Door Removal**

1. Remove heater plug from back of raceway.

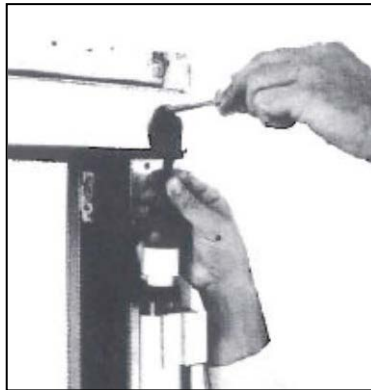

2. Remove front door. Move door to center of frame.



3. If optional spring closers are in place, unhook spring from hook on top of door before removing door.



4. Grasp each side of door and lift door up into top track. Make sure bottom roller cage has released from bottom of door. Pull bottom of door outward and gently let door down slowly.



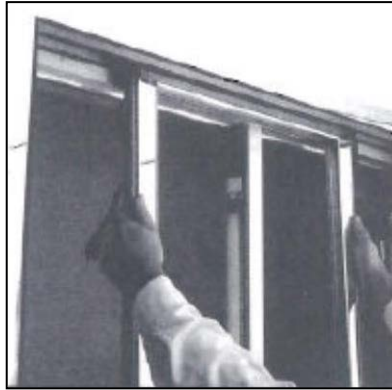

5. Repeat instructions above for rear door.

**V. Ordering Replacement Doors**

1. Specify outside dimensions of door (measure to nearest 1/16"). See A & B in the following illustration.

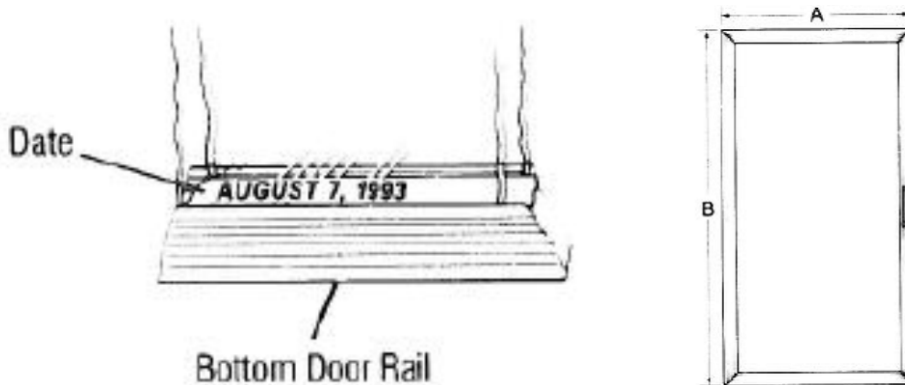

2. With or without heaters?
3. With or without self-closers?
4. Specify finish.
5. Specify any custom items on original order. (Original manufacture date is stamped on metal spacer bar between panes of glass, as indicated in above drawing.)
6. Specify voltage.
7. With or without locks?
8. Specify handle type (Decorator, 6" or 13" metal). Specify handle color.

**VI. Ordering Replacement Frames**

1. Specify outside dimensions of door (measure to nearest 1/16"). See A & B in the following illustration.

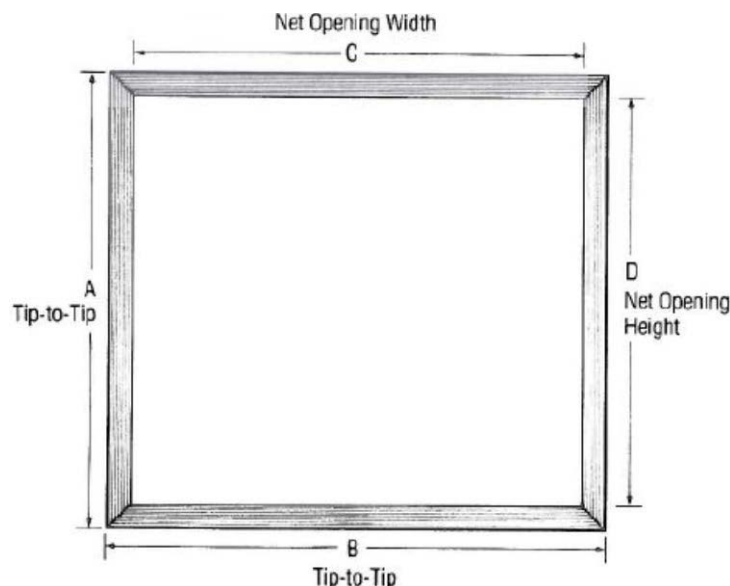

- 2. With or without heaters?
- 3. Specify finish.
- 4. With or without self-closers?
- 5. Date of original order and/or Anthony confirmation/invoice number.
- 6. Specify junction box location.
- 7. Specify voltage.

**VII. Door Plastic (Cover) Replacement**

- 1. Insert flat-head screwdriver under outside corner edge of door plastic and gently pry up. At either end of plastic, run screwdriver the complete length and width of door rail. With outside edge of plastic released, push plastic toward glass to remove.

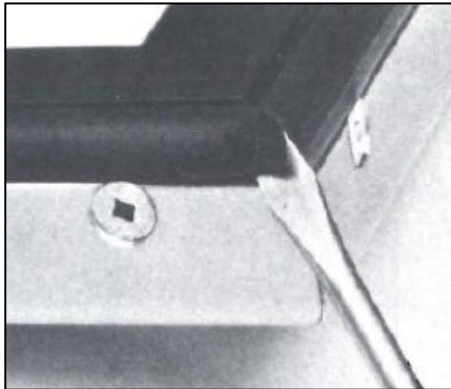

- 2. To replace, insert inside edge of plastic (closest to glass) into inside edge of door rail. Then snap outside edge of plastic over outside edge of door rail.

**VIII. Door Handle Replacement**

- 1. Insert flat-head screwdriver under handle side edge of plastic at corner of door and gently pry up.

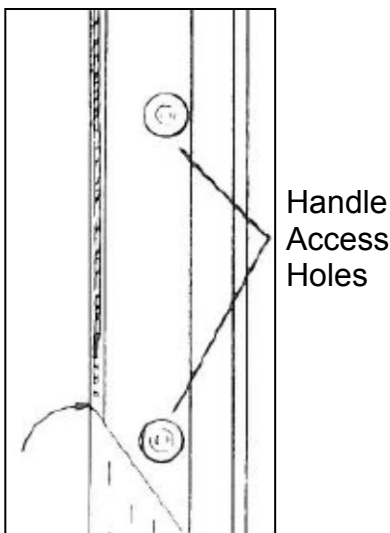

2. Depending on handle, insert a 5/32" or 1/4" Allen wrench into access hole on back side of handle rail. Remove screws.
3. Reverse instructions to replace.
4. ***Do not use power tools for installation or removal.***

**IX. Models 1100/1500 Cross-Section Construction & Dimensions**

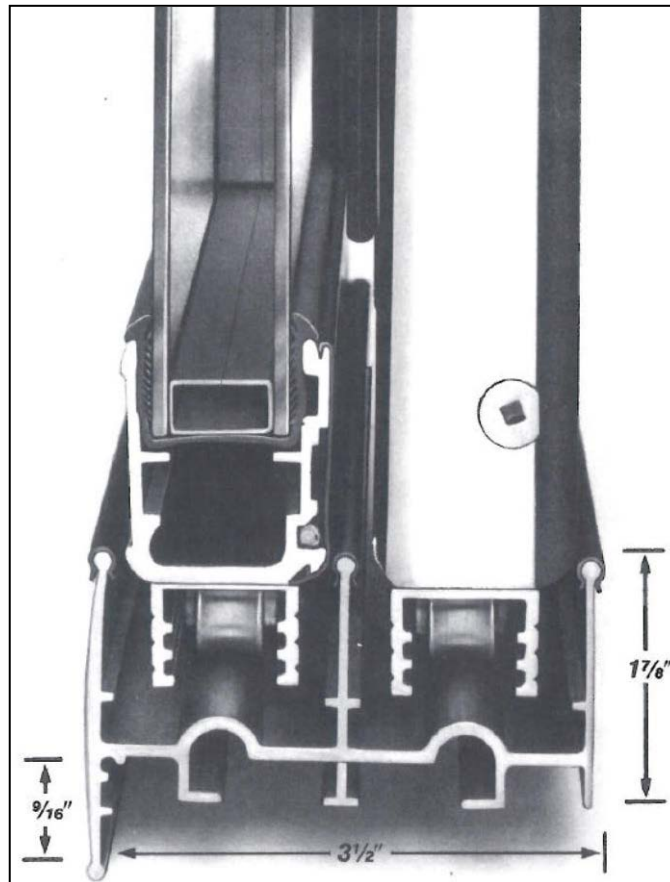

**X. Roller Cage Replacement**

1. Remove door from frame.
2. Remove bottom of roller cage from bottom of door and measure from end to end. Roller cage is the same width as door.

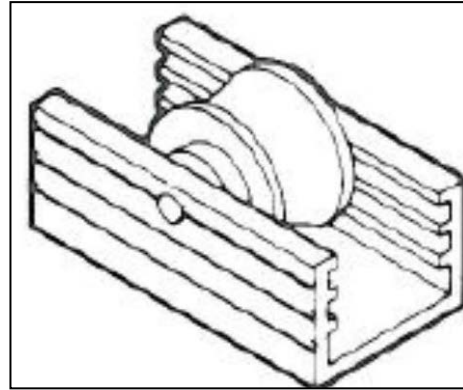
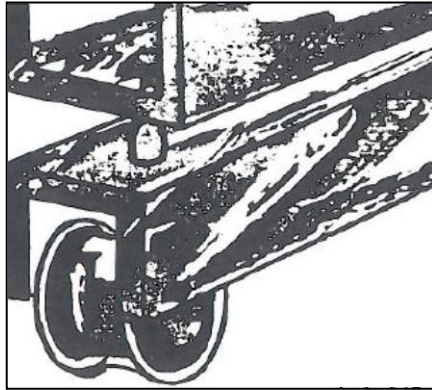

3. Reverse instructions to replace.

**XI. Door Lock Installation**

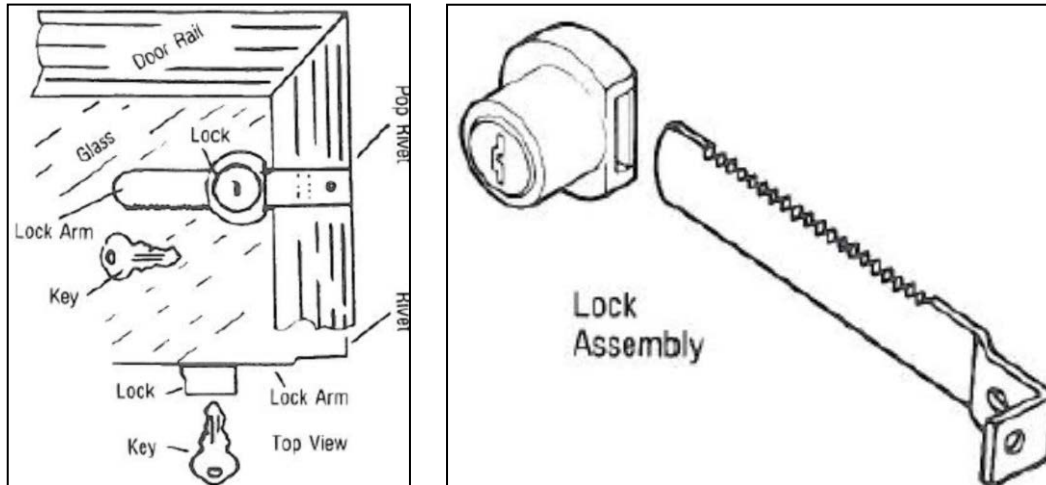

1. Lock arm mounts on hinge side (opposite of handle side) of inside door.
2. Locate lock arm on center of side door rail.
3. Hook arm over edge of door rail 1/2" and mark both holes in lock arm.
4. Pre-drill rivet or screw hole.
5. Serrated edge of lock arm goes toward bottom of door.
6. To attach arm to door rail, use a 1/8" pop rivet or other.
7. Lock device fits into lock arm.

**XII. Door Heater Replacement and/or Door Plug Replacement**

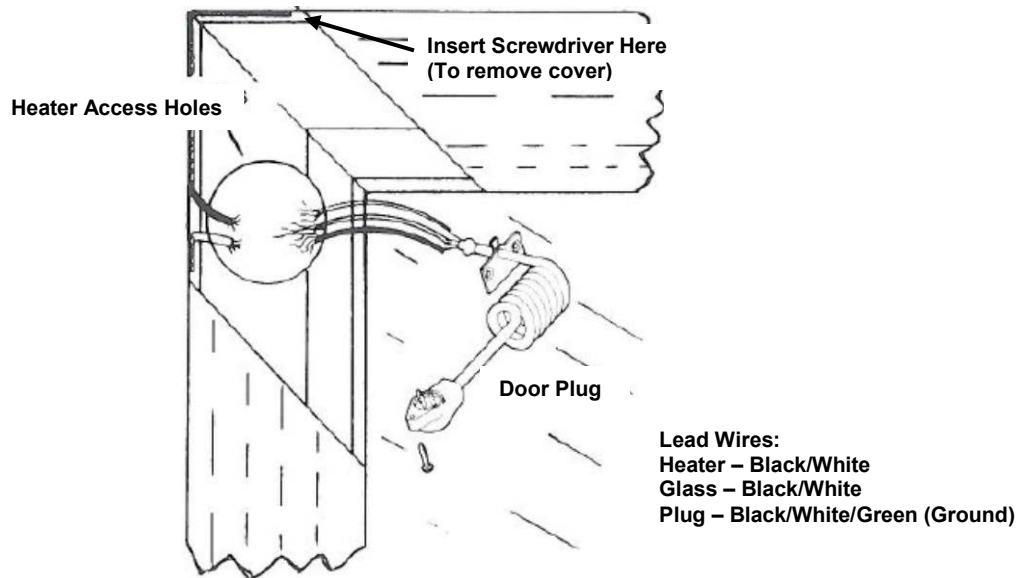

1. Remove the door plastic.

2. After removing the door plastic, go to handle side top corner of door. Insert Phillips-head screwdriver, and unscrew to remove plug and strain relief.
3. Cut Black, White and Green (ground) lead wires to remove plug. If heater is defective, simply pull heater out and away from back track in door.
4. If door has heated glass, cut Black and White lead wires to glass.
5. Reverse instructions to replace plug. (Replacement cord is ordered according to width of door.)
6. To replace heater, lay heater wire in track around outside back edge of door rail. Connect plug to heater access hole and re-install door plastic.
7. Wiring instructions are: Black to Black, White to White and Green to ground.
8. If glass is heated, re-wire Black & White lead wires from plug to Black and White lead wires from glass.
9. ***Do not use power tools for installation or removal.***

**XIII. Frame Heater Replacement**

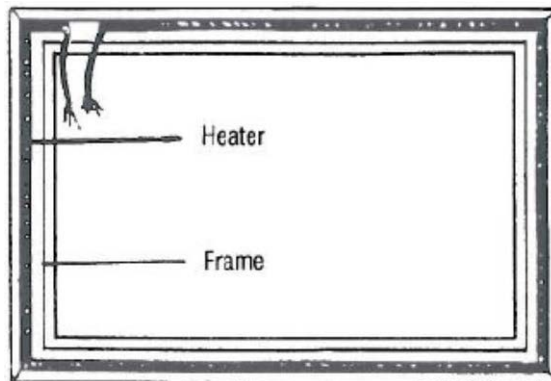

1. Remove frame from opening.
2. Insert flat-head screwdriver under edge of frame plastic to remove.
3. Frame heater lies in track around perimeter of frame. Reverse instructions to replace.

**XIV. Frame Gasket Replacement (Prior to 1985)**

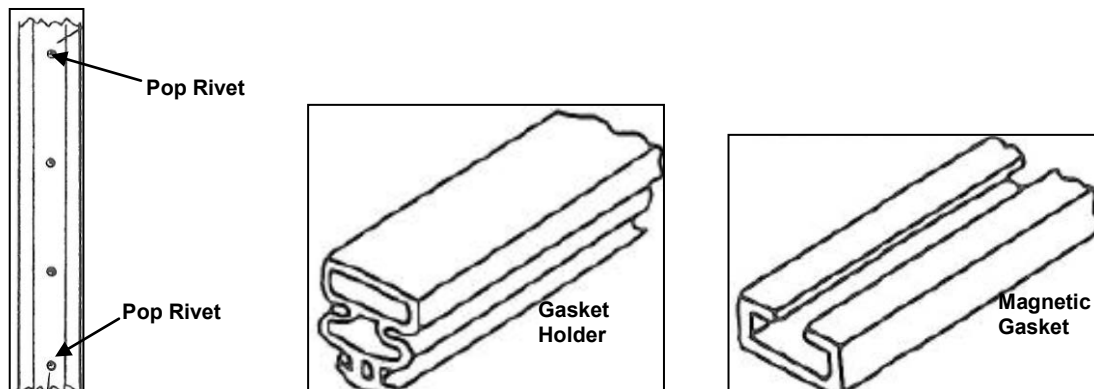

1. Frame gasket is on handle side of door. To remove, drill out pop rivets on top and bottom of rubber gasket, then slide gasket out of plastic retainer.
2. To replace, slide new gasket into plastic retainer. Rivet back in place.
3. Magnetic stainless is located inside end of frame.
4. To replace frame stainless steel, drill out pop rivets and remove. (If Phillips-head screws were used, unscrew.) Reverse instructions to install new stainless.
5. To replace rubber flaps on back of door, simply slide rubber flaps out from end and insert new flaps.

**XV. Frame Gasket Replacement (1985 to Present)**

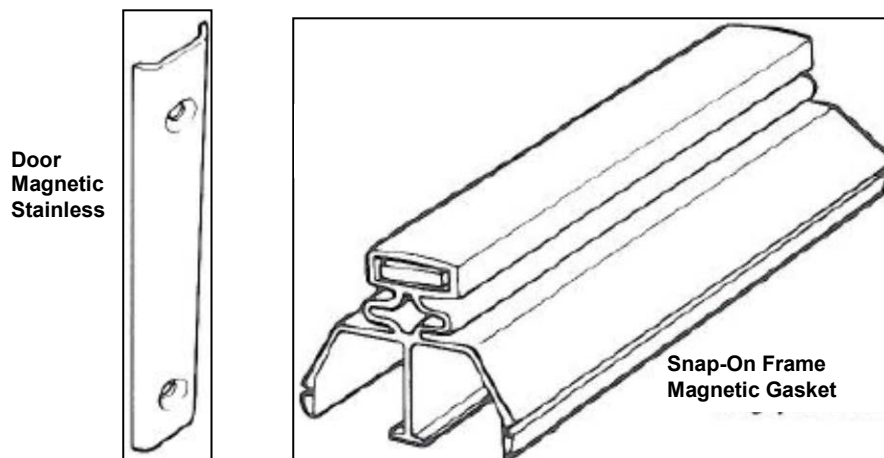

1. Gaskets are located in the frame. Door has magnetic stainless to attract to frame gasket. To remove, compress sides of gasket and pull gasket outside of frame.
2. To replace gasket, compress sides of gasket and snap into end frame extrusion.
3. Magnetic stainless is located on the door.
4. To replace door stainless steel, drill out pop rivets and remove. (If Phillips-head screws were used, unscrew.) Reverse instructions to install new stainless.
5. To replace rubber flaps on back of door, simply slide rubber flaps out from end and insert new flaps.

**XVI. Frame Female Plug Replacement**



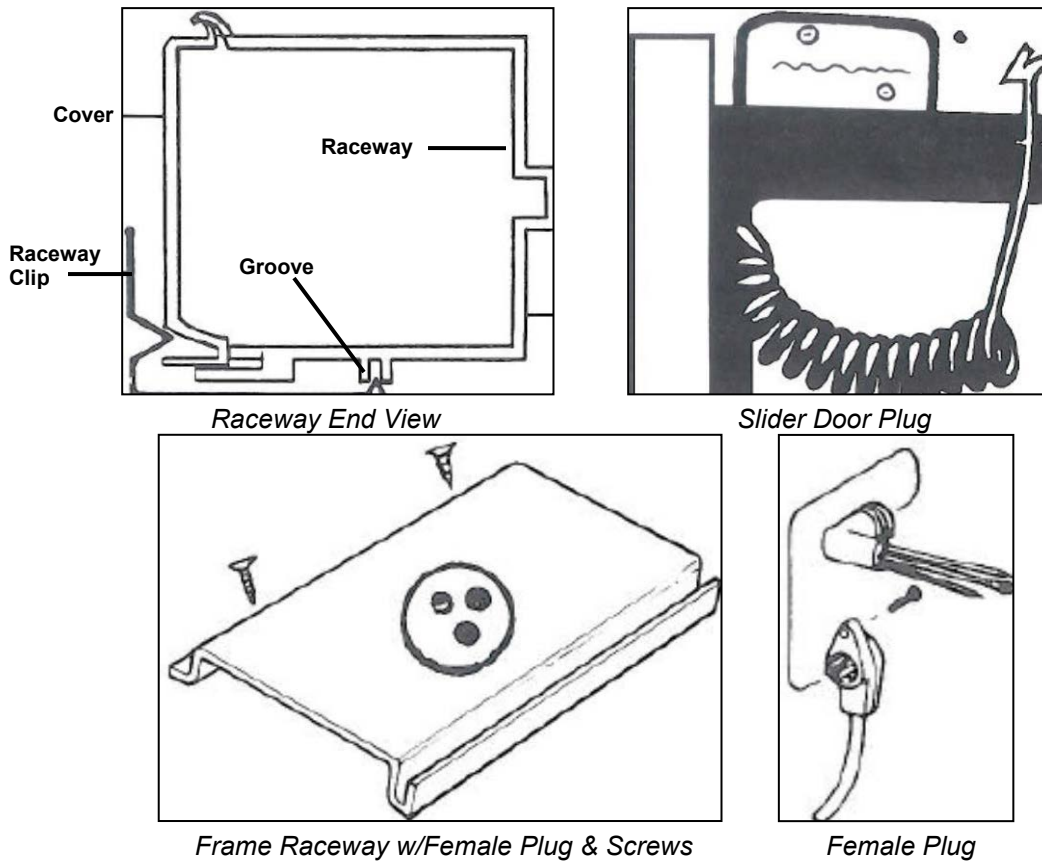

1. Female plug is located on top back side of frame.
2. **(Prior to 1984)** To remove raceway, insert small flat-head screwdriver under edge of raceway clip to remove female plug. With raceway removed, reach in and pull female plug away from raceway cover.
3. **(1984 to June 1993)** Remove Phillips-head screws to remove raceway. With raceway removed, reach in and pull female plug away from raceway cover.
4. **(June 1993 to Present)** A new clip was designed to secure raceway cover. To remove, insert flat-head screwdriver under edge of clip to unsnap. With raceway removed, reach in and pull female plug away from raceway cover.
5. Cut lead wires; Black, White and Green.
6. To replace, re-wire female plug Black to Black, White to White and Green to ground.

**XVII. Pre-Wired Ballast Replacement**

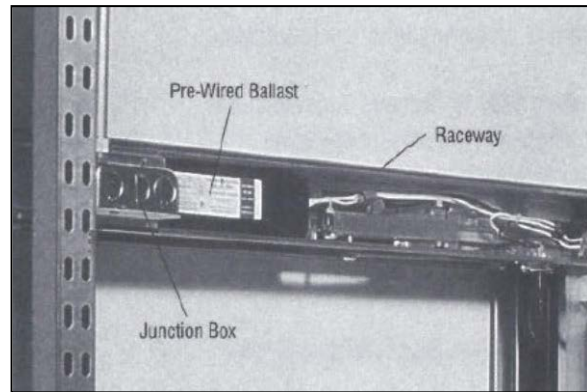
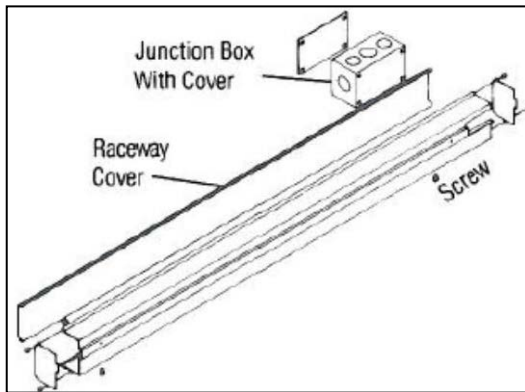

1. Go to back top of raceway.
2. **(1984 to June 1993)** To replace raceway, remove Phillips-head screws. To remove retainer strip, insert flat-head screwdriver under back edge and gently pull up.
3. **(June 1993 to Present)** A new clip was designed to hold raceway cover in place. To remove, insert flat-head screwdriver under top edge of clip to unsnap.
4. Ballasts are exposed.
5. Cut lead wires and remove ballast.
6. To replace, insert new ballast and re-wire to ballast schematic located on ballast, following color-coded wiring.

**XVIII. Bulb Replacement**

1. To remove bulb, lift bulb up into top socket and out at the bottom.
2. To replace, lift bulb up into spring loaded top socket, in and down into bottom socket.

**XIX. Lamp Socket Replacement**

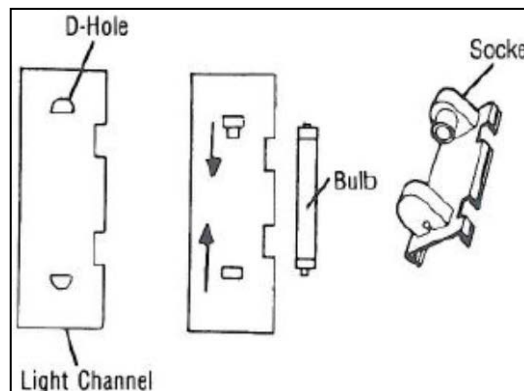

1. To remove top socket, pull socket down and out. Sockets have extra lead wire for easy replacement.
2. Cut two (2) Blue lead wires and re-wire new socket.
3. To replace top socket, insert tab on bottom of socket into “D” hole punched in light channel and push socket up.

- 4. For bottom socket, pull socket up and out.
- 5. Cut two (2) Red lead wires and re-wire new socket.
- 6. To replace bottom socket, insert socket tab on bottom of socket into “D” hole punched in light channel. Push down and snap into place.
- 7. To re-wire new sockets, follow color-coded lead wire. (Top socket has two (2) Blue wires, bottom socket has two (2) red wires.)

**XX. Models 1100 & 1500 (120-Volt) Ballast Wiring Diagram**

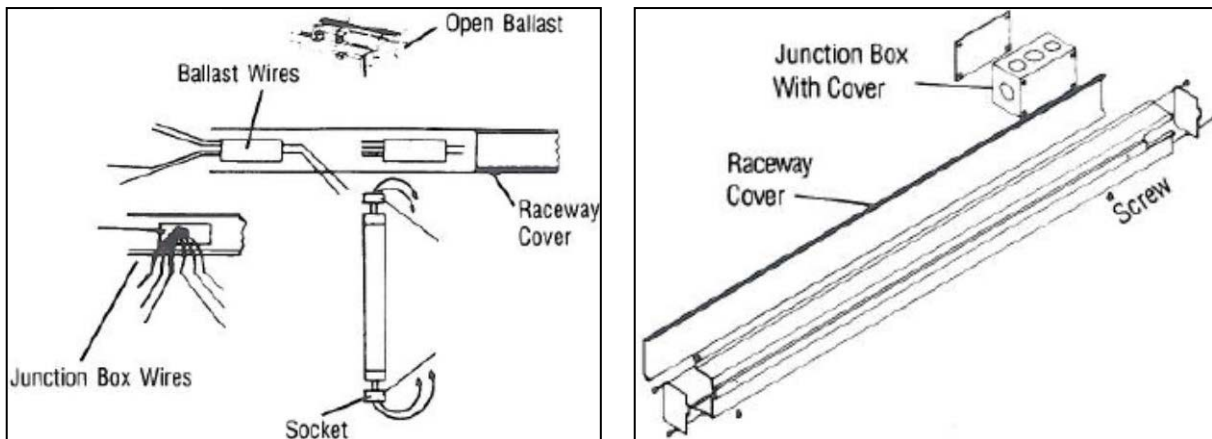

**XXI. Shelving Installation (Prior to 1984)**

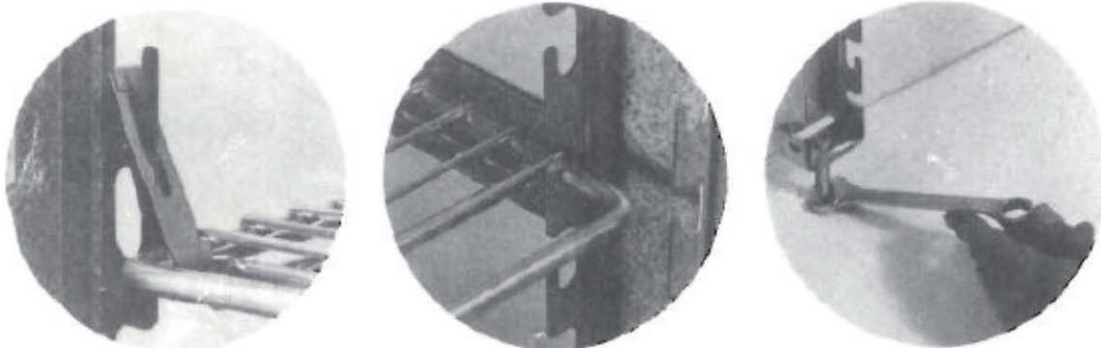

1. Insert shelf over sawtooth edge on back of front post.
2. Insert clip on back of shelf over back of rear post grooves as shown above.
3. Using an open-end wrench, level rear posts. Turn bolt on bottom of rear posts counter-clockwise to level, as shown above.
4. Protector channels must be cut to desired lengths after shelving has been positioned. Protector channels snap over vertical shelf standards.

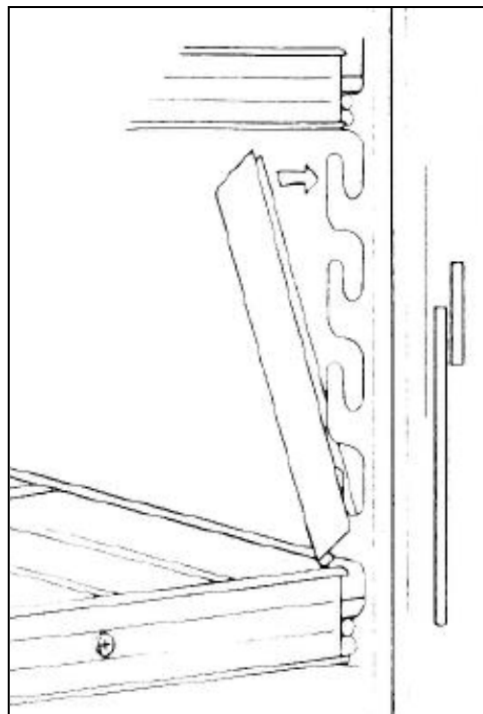

For details, refer to the following:

- 5. Front and rear post safety cover, with light and front shelf post assembly (**L-1649**).

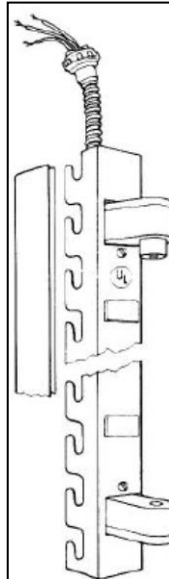

- 6. Replacement shelving.

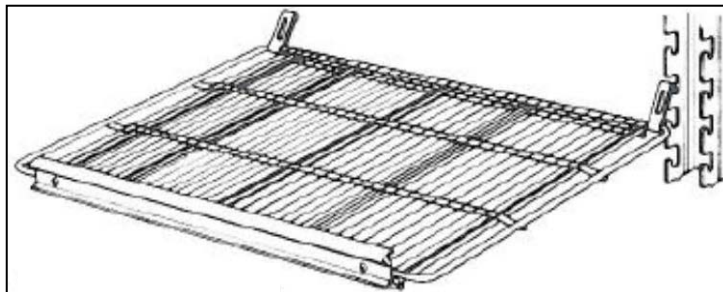

26" Deep Shelf – White Only  
(Old Style – Before '84)  
22-3/4" x 26" **S-4031A**  
26-1/2" x 26" **S-4031B**  
28-1/2" x 26" **S-4031C**  
30" x 26" **S-4031D**  
(Specify Tag: Gold, Silver, White)

- 7. Rear post w/adjustment bolt and bracket (**S-4015**).

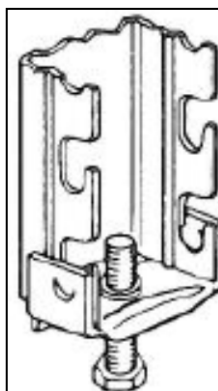

- 8. Price tag molding attachment clip (**S-4002**).

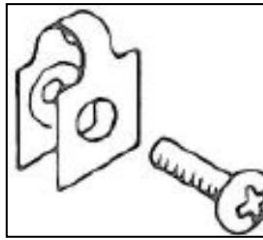

9. Rear swing clip (**S-4000**).

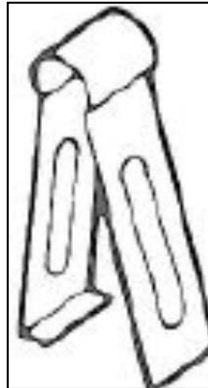

**XXII. Four-Post Stabilizer Bar Installation**

1. The four-post stabilizer is designed to help support the posts during installation and stabilize the system while in use.

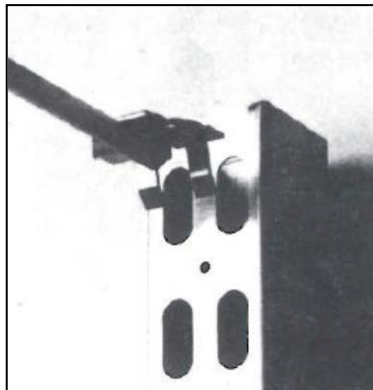

2. Insert the forked end of stabilizer bar into the elongated holes in post.

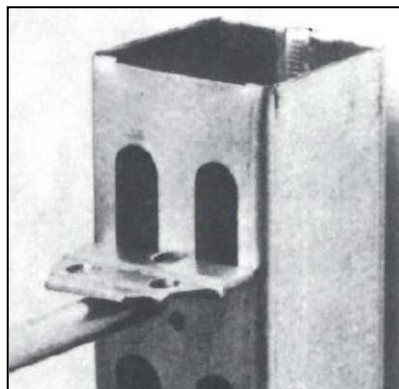

3. Install the post stabilizers on the top and bottom of all posts, front to rear, before installing shelves.

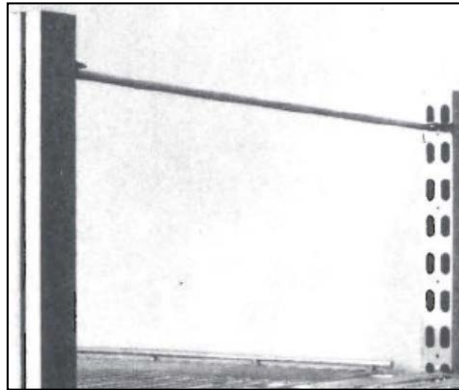

**XXIII. Four-Post Shelf System Installation**

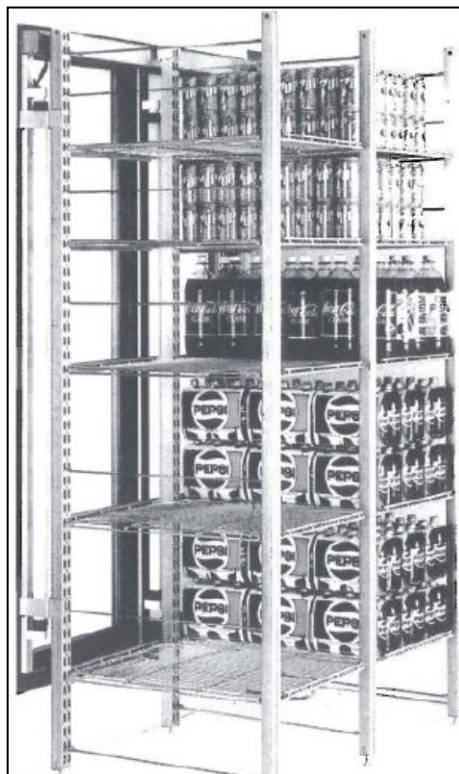

1. Insert post key into frame retaining bracket to install post to door frame.

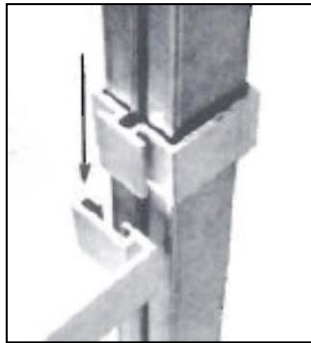

2. The four-post stabilizer is designed to help support the posts during installation and stabilize the system while in use.
3. Insert the forked end of stabilizer bar into the elongated holes in post.
4. Before installing shelves, install the post stabilizers on the top and bottom of all posts, front to rear.
5. Before installing shelves, adjust all front posts to equal heights with leg leveling bolts at bottom of posts.

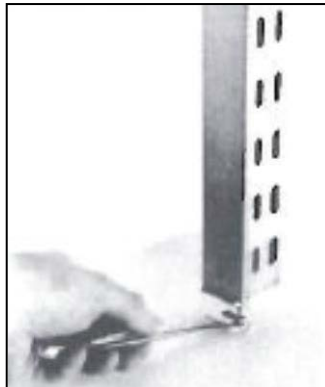

6. Insert front of shelf in front post at angle as shown. Position rear shelf posts.

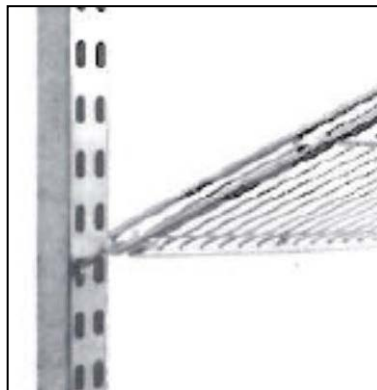

7. Drop rear of shelf down and pull back in slot on rear posts. Continue to add shelves behind each door, spacing for desired product merchandising.



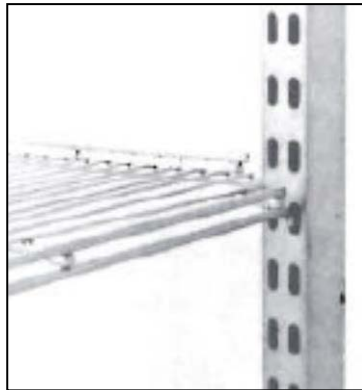

8. After installing shelves, adjust rear post leveling bolts to level. The four-post system is now ready for merchandising.

**XXIV. Plastic Tag Molding Installation**

1. Tag molding is the exact length of the shelf's upper front bar. Center tag molding on front of shelf. Hook bottom of tag molding under shelf across entire width of shelf. Spread thumbs across tag molding and push up.

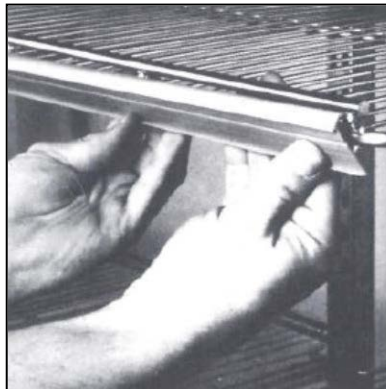

2. Snap top corner of tag molding strip onto shelf front. Apply even pressure across top of tag molding as it is fed onto top horizontal bar on shelf front.

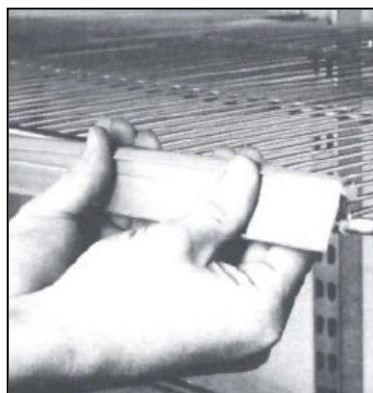

3. For replacement tag molding, indicate width of shelf when ordering.

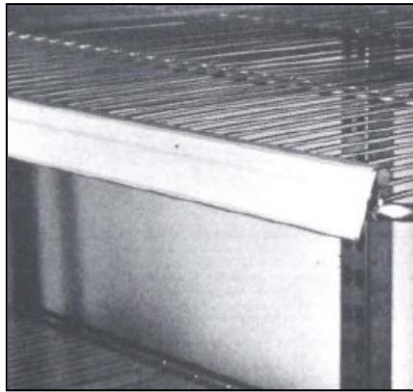

**XXV. Model 1100 Shelf Assembly**

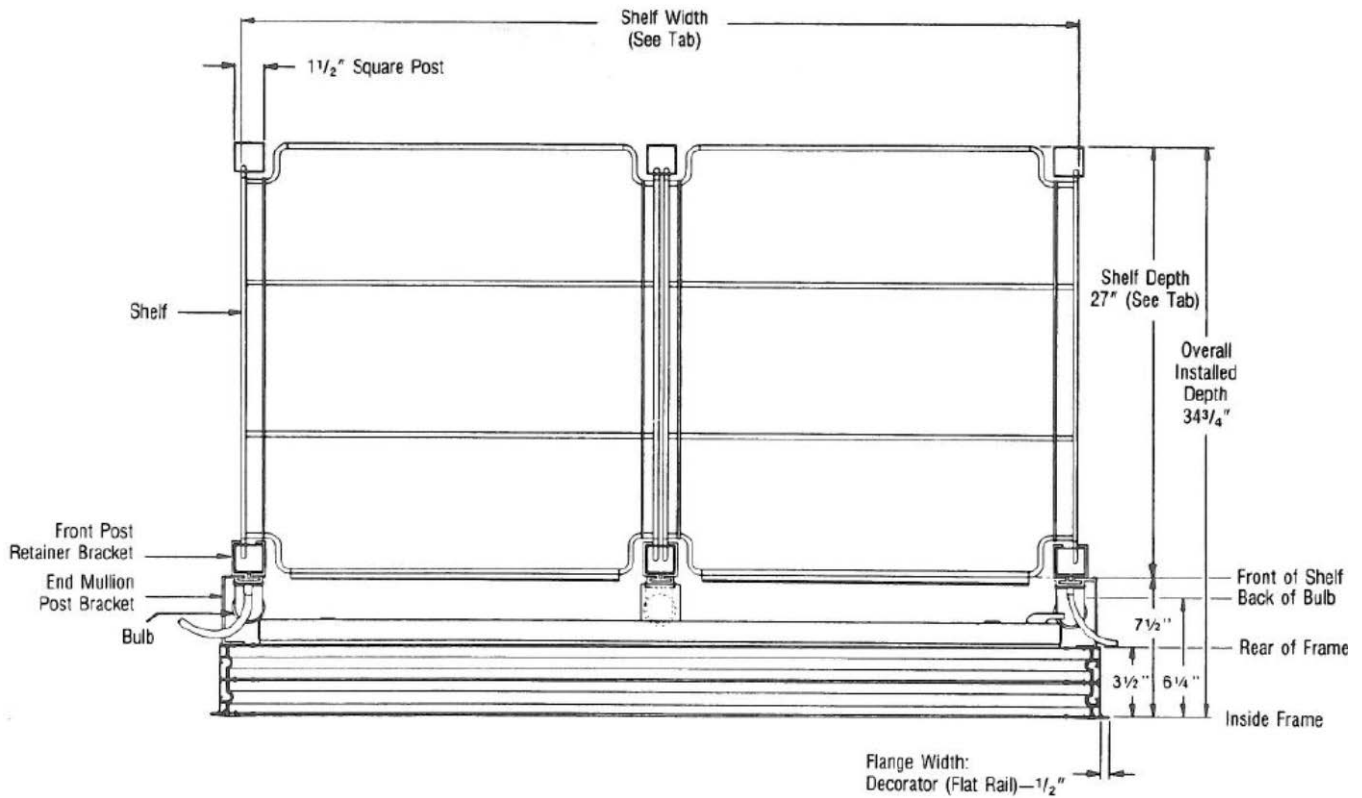

SHELF TABULATION	
SHELF WIDTH:	
22.56"	(22 9/16")
26.31"	(26 5/16")
28.31"	(28 5/16")
29.81"	(29 13/16")

**XXVI. Glass Replacement (Reglazing)**

1. Insert flat-head screwdriver under outside edge of door plastic and gently pry up. At either end of plastic, run the screwdriver the complete length and width of door rail. With outside edge of plastic released, push plastic toward the glass to remove.

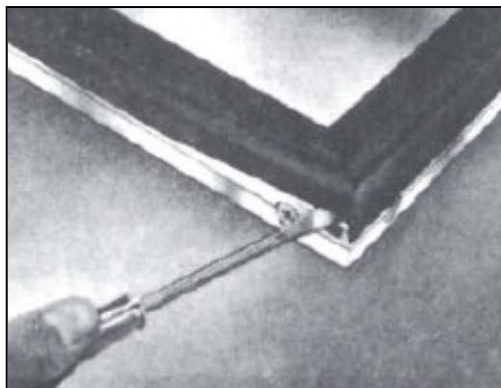

2. Unscrew SJ Cord retainer to expose heater wires. If heated glass is used, cut Black and White wires to glass. Remove heating element from door.

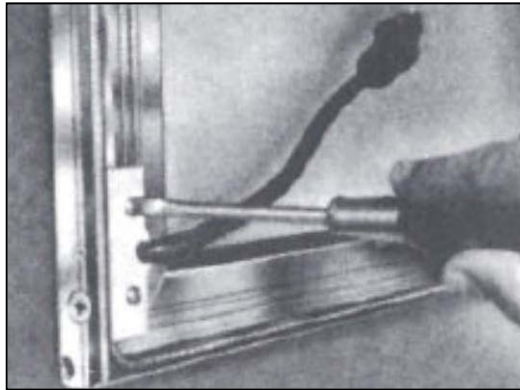

3. Using square-head or clutch-head driver, remove screws from both sides of rail only. Remove top and bottom rails first.

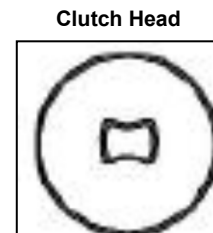
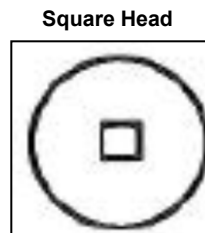
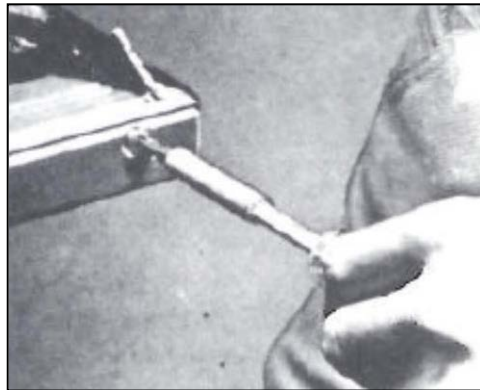

4. Always starting at the corner of the door, drive rails from glass using a mallet and block.

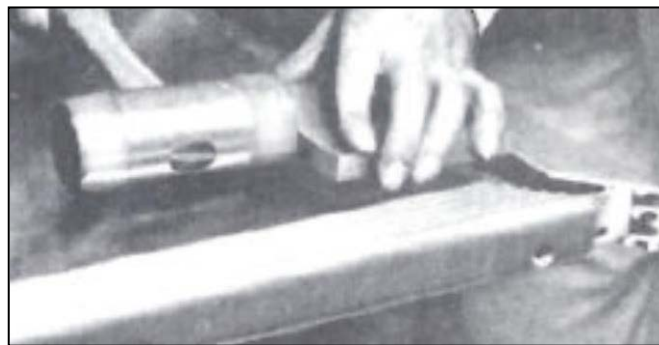

5. When rails have been removed from glass, re-insert new friction-fit glazing channel on new glass. Using a mallet and block, drive rails on to glass.

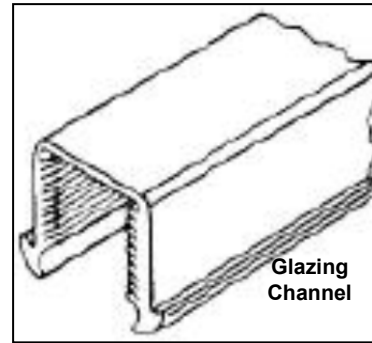

6. After both long rails have been affixed to glass, re-insert friction-fit glazing channel on top and bottom. Tighten miters with square-head or clutch-head driver.



7. After door has been re-built, measure door diagonally to check for square.



8. After the glass unit has been replaced and door rails are in square, re-insert heater wires in door rail and replace the retaining strips.

**Note:** If heated glass is used, when dis-assembling door, cut Black and White lead wires to glass. When re-building door, pull glass heater leads out through heater access hole before assembling top or side door rail. Re-connect Black to Black, White to White.

XXVII. Humastat Installation

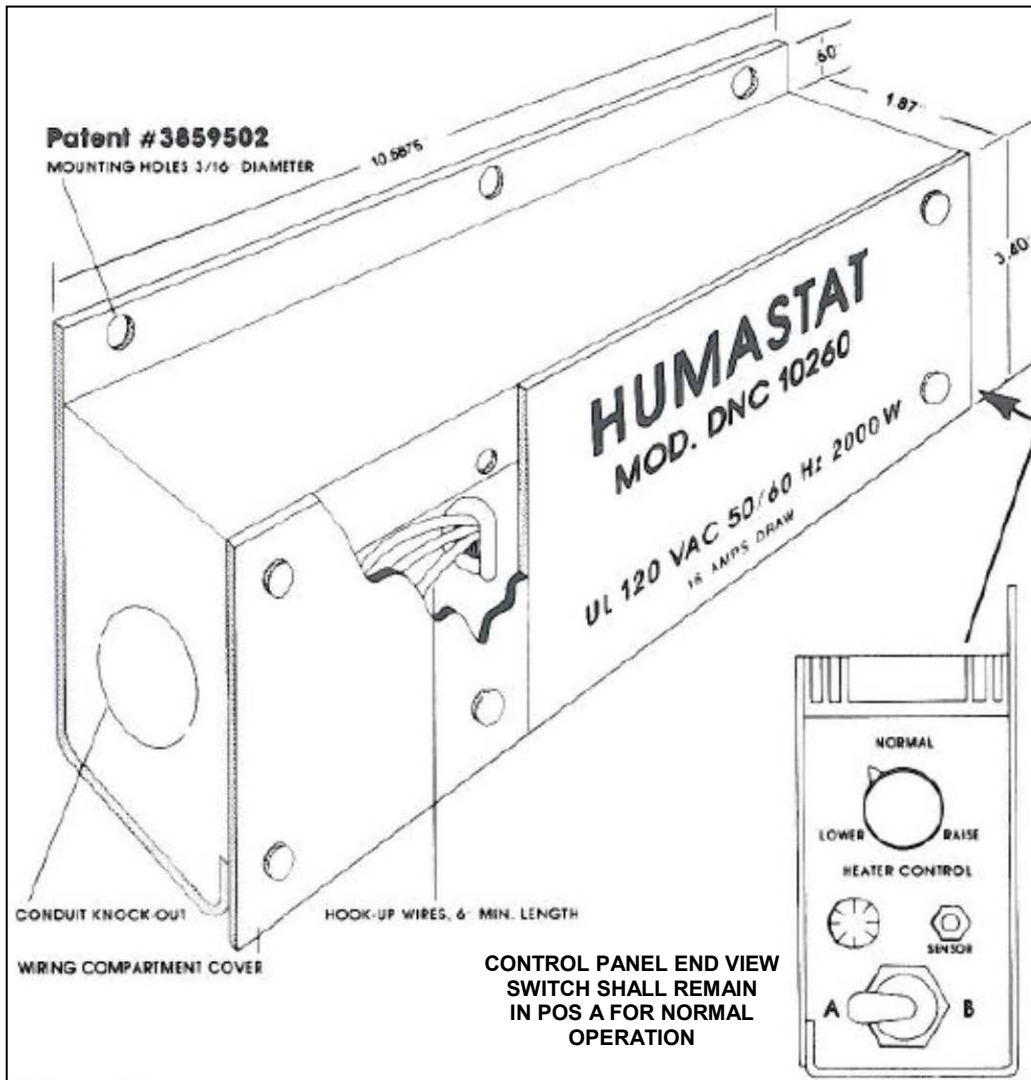

1. Install Humastat Power Junction Box before refrigerator door power wiring, on the inside wall of refrigerator.

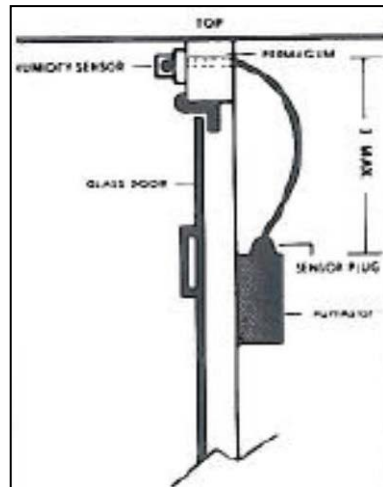

2. Remove wiring compartment covers by removing four (4) sheet metal screws.
3. Connect heater hot wire to Red wire from control unit.

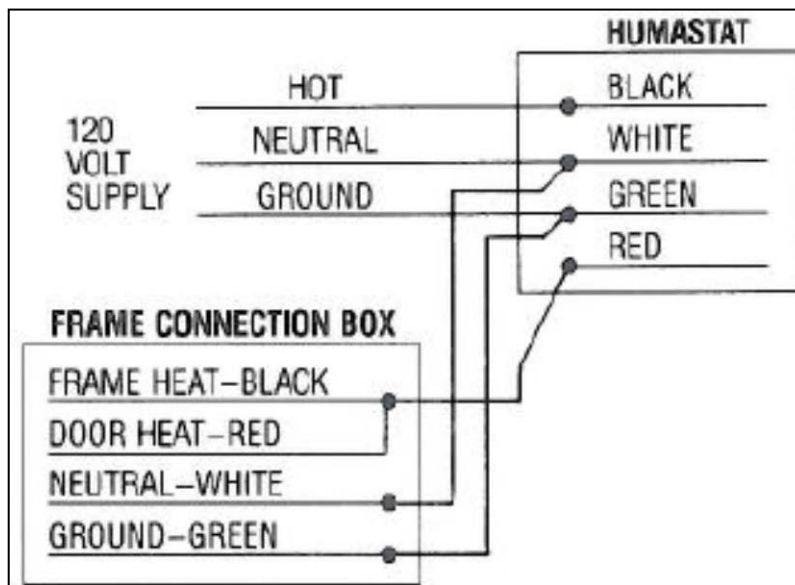

**Wiring Diagram**

4. Connect input power hot wire to Black wire from control unit.
5. Connect all White wires, including common side of power line, line load and control unit White wire.
6. Connect Green Ground wire from control unit to Green Ground wire at frame and to incoming Ground wire (if furnished).
7. Replace the Wiring Compartment Cover with the sheet metal removed in No. 2 above.
8. Install Humastat Sensor on the outside wall of refrigerator above the door frame, within three (3) feet of power junction box.

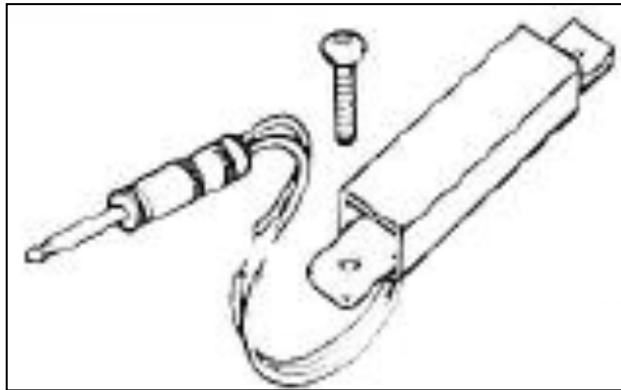

- a. Drill a 1/4" diameter hole through refrigerator wall directly above the door frame.



- b. Use the wood probe supplied with the sensor to feed the sensor wire through the refrigerator wall.

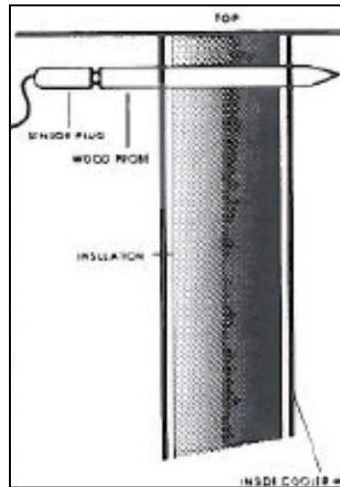

- c. Apply permagum to back of sensor around wire. Pull the wire through the hole until the sensor makes solid contact with the wall, and secure it to the wall with the screws provided. Also seal probe wire with the permagum on inside of wall.
9. Remove wood probe from sensor connector by holding the body of connector securely and pulling off the probe.
  10. Insert the sensor plug into the sensor jack on the outside end of the power junction box.
  11. Set the heater control knob for the lowest value which keeps the door free of undesirable moisture.
  12. Red light indicates when heaters are functioning.

**XXVIII. Electrical Information for Model 1100 Normal Temp Doors, Frames & Light Fixtures – Amperages at 120 Volts**

NET OPENING	NO. DOORS	DOOR AMPS	FRAME AMPS	TOTAL HEAT AMPS	AMPS PER LAMP
<b>STYLE:</b> NORMAL TEMP DOORS WITH HEATERS, 2-PANE NHG (Non-Heated Glass)					
<b>APPLICATION:</b> CASE TEMPERATURE 36°F; IN-STORE AMBIENT OF 75°F and 65% RELATIVE HUMIDITY					
49 ¼ X 54	2	0.32	0.39	1.04	0.55
71 1/16 X 54	3	0.32	0.49	1.45	0.55
49 ¼ X 67	2	0.37	0.45	1.20	0.55
71 1/16 X 67	3	0.37	0.53	1.65	0.55
49 ¼ X 73	2	0.41	0.50	1.31	0.55
71 1/16 X 73	3	0.41	0.56	1.78	0.55
56 ¾ X 54	2	0.33	0.44	1.10	0.55
82 5/16 X 54	3	0.33	0.54	1.52	0.55
56 ¾ X 67	2	0.39	0.49	1.28	0.55
82 5/16 X 67	3	0.40	0.57	1.76	0.55
56 ¾ X 73	2	0.41	0.51	1.33	0.55
82 5/16 X 73	3	0.41	0.63	1.86	0.55
60 ¾ X 54	2	0.36	0.46	1.17	0.55
88 5/16 X 54	3	0.36	0.54	1.62	0.55
60 ¾ X 67	2	0.41	0.52	1.33	0.55
88 5/16 X 67	3	0.41	0.63	1.85	0.55
60 ¾ X 73	2	0.43	0.52	1.37	0.55
88 5/16 X 73	3	0.43	0.64	1.93	0.55
63 ¾ X 54	2	0.35	0.44	1.15	0.55
92 3/16 X 54	3	0.35	0.55	1.62	0.55
63 ¾ X 67	2	0.40	0.51	1.31	0.55
92 3/16 X 67	3	0.40	0.61	1.81	0.55
63 ¾ X 73	2	0.42	0.53	1.37	0.55
92 3/16 X 73	3	0.42	0.63	1.89	0.55

- Notes:**
1. All amperages are design amperages subject to the following tolerances: units with rail heaters only, +/- 5%; units with rail heaters and heated glass +/- 8%.
  2. Although the amperages are calculated at 120 volts, all doors are designed to operate without sweating when used within the application parameters with a voltage range of +/- 10%.
  3. When calculating lamp amperage, add one (1) lamp to the number of doors in the line-up and multiply that number by the appropriate amps per light value.
  4. Design parameters do not make allowances for factors such as air leaks or unusual air flow patterns within cases; therefore, some sweating may occur when upper limits of temperature or humidity are encountered.

**XXIX. Electrical Information for Model 1500 Normal Temp Doors, Frames & Light Fixtures – Amperages at 120 Volts**

NO. DOORS	NO. FRAMES	WIDTH	60" HIGH	72" HIGH	73" HIGH	84" HIGH
<b>STYLE: NORMAL TEMP DOORS WITH HEATERS, 2-PANE NHG (Non-Heated Glass)</b>						
<b>APPLICATION: CASE TEMPERATURE 36°F; IN-STORE AMBIENT OF 75°F and 65% RELATIVE HUMIDITY</b>						
2	1	4'	1.52	1.72	1.71	1.89
2	1	5'	1.66	1.80	1.85	2.09
2	1	6'	1.78	2.00	2.09	2.21
2	1	7'	1.98	2.15	2.13	2.38
2	1	8'	2.05	2.29	2.35	2.51
2	1	9'	2.23	2.40	2.38	2.68
2	1	10'	2.32	2.65	2.63	2.77
4	2	11'	3.50	3.92	3.90	4.28
4	2	12' 7/8"	3.56	4.00	4.18	4.42
4	2	13'	3.70	4.18	4.14	4.50
4	2	14' 7/8"	3.96	4.30	4.26	4.76
4	2	15'	4.10	4.36	4.36	4.80
4	2	16' 7/8"	4.10	4.58	4.70	5.02
4	2	17'	4.26	4.62	4.66	5.06
4	2	18' 7/8"	4.46	4.80	4.76	5.36
4	2	19'	4.46	5.02	4.98	5.58
4	2	20' 7/8"	4.64	5.30	5.26	5.54
6	3	21' 1 3/4"	5.94	6.45	6.39	7.14
6	3	22'	5.82	6.51	6.57	7.21
6	3	23'	6.09	6.87	6.99	7.29
6	3	24' 1 3/4"	6.15	6.87	7.05	7.53

- Notes:**
1. All amperages are design amperages subject to the following tolerances: units with rail heaters only, +/- 5%.
  2. Although the amperages are calculated at 120 volts, all doors are designed to operate without sweating when used within the application parameters with a voltage range of +/- 10%.
  3. Design parameters do not make allowances for factors such as air leaks or unusual air flow patterns within cases; therefore, some sweating may occur when upper limits of temperature or humidity are encountered.

**XXX. Heat Load in BTU/Hr for Model 1100 Glass, Door Rail, Frame Heaters & Lights (Per door with Doors Closed at 75°F Store Ambient)**

MODEL 1100 NORMAL TEMPERATURE (2-PANE NHG – CASE TEMP 36°F)		
NET OPENING (W x H)	2 DOOR	3 DOOR
48 x 54	1.66	2.09
48 x 67	1.78	2.21
48 x 73	1.98	2.38
55 x 67	2.05	2.51
55 x 73	2.23	2.68
59 x 54	2.32	2.77
59 x 67	3.50	4.28
59 x 73	3.56	4.42
62 x 54	3.70	4.50
62 x 67	3.96	4.76
62 x 73	4.10	4.80
48 x 36	4.10	5.02
62 x 36	4.26	5.06

**Note:** Add 10 – 20% to above values depending on door opening frequency.

**XXXI. Heat Load in BTU/Hr for Model 1500 Glass, Door Rail, Frame Heaters (with Doors Closed at 75°F Store Ambient)**

MODEL 1500 NORMAL TEMPERATURE (2-PANE NHG – CASE TEMP 36°F)				
NET OPENING WIDTH	60" HIGH	72" HIGH	73" HIGH	84" HIGH
4'	935	954	953	974
5'	1132	1149	1161	1180
6'	1325	1352	1359	1392
7'	1527	1561	1557	1590
8'	1733	1766	1762	1783
9'	1935	1964	1963	1976
10'	2140	2150	2162	2191
11'	4443	4489	4503	4554
12' 7/8"	4849	4903	4915	4982
13'	5206	5257	5268	5324
14' 7/8"	5614	5681	5674	5740
15'	5965	6042	6036	6088
16' 7/8"	6389	6468	6447	6488
17'	6745	6803	6799	6857
18' 7/8"	7153	7211	7209	7235
19'	7521	7567	7575	7646
20' 7/8"	7925	7945	7969	8027
21' 1 3/4"	12261	12361	12351	12450
22'	12760	12836	12828	12899
23'	13333	13396	13390	13466
24' 1 3/4"	13966	14063	14053	14114

**Note:** Add 10 – 20% to above values depending on door opening frequency. With light fixtures installed, add 200 BTU/light.

**XXXII. Dew Point Chart**

NORMAL TEMPERATURE APPLICATIONS						
GLASS TYPE	ROOM TEMP (F)	CASE TEMPERATURE (F)				
		40	35	30	25	20
TWO PANE NHG	70	70	66	61	58	53
	75	67	62	59	55	52
	80	63	60	57	53	50
	85	60	58	53	50	49
	90	58	55	52	49	47
THREE PANE NHG	70	74	71	68	65	62
	75	72	68	66	63	60
	80	68	66	63	60	58
	85	66	64	61	58	56
	90	65	62	59	57	54
TWO PANE REFL NHG	70	76	75	70	67	63
	75	75	70	69	66	62
	80	70	68	66	62	59
	85	68	66	63	60	58
	90	67	64	60	58	56
TWO PANE HEATED GLASS	70	98	92	90	84	80
	75	95	90	86	84	77
	80	90	85	81	76	73
	85	86	80	78	72	69
	90	82	78	74	70	66

NHG = Non Heated Glass      % RELATIVE HUMIDITY @ WHICH CONDENSATION FORMS ON GLASS

Calculations make no allowance for air leaks or unusual air flow patterns within cases and are intended to be used as guidelines only.

**XXXIII. Troubleshooting**

1. **Electrical:** Low voltage supply (less than 108V on 120V systems) results in significantly lower wattage. Lower wattage will decrease the efficiency of heaters and lamps.

A. Glass Condensation:

1. No Power? Check:
  - a. Power supply
  - b. Relative humidity in room area
  - c. Case temperature
  - d. Incorrect wiring
2. Low Voltage? Check voltage at main power source.

**B. Door and Frame Rail Condensation:**

1. No Power? Check:
  - a. Power supply
  - b. Relative humidity in room area
  - c. Case temperature
  - d. Incorrect wiring
2. Low Voltage? Check voltage at main power source.

**2. Mechanical:**

**A. Door Not Sealing? Check:**

1. Magnetic gasket (Replace if necessary)
2. Defective frame plastic
3. Frame or door out of square

**B. Door Will Not Close?**

1. See instructions 2a, 1 through 3

**C. Door Saw Toothed?**

1. Door or frame out of square? (Square to the nearest 1/16" of net opening)
2. Case not level?
3. Frame not shimmed properly?

**3. Ballast/Lamps:**

**A. Door Not Sealing? Check:**

1. Ballast failure?
2. Incorrect ballast?
3. Incorrect wiring?
4. Incorrect bulb?
5. Poor contact between bulb and socket?
6. Case too old? (Lamps will usually light, but they will be very dim)
7. Incorrect socket wiring?
8. No ground?

**B. Lamp Flickering:**

1. Incorrect ballast?
2. Defective bulb?
3. Incorrect voltage?
4. Bulbs without shields?

**C. Slow-Starting Bulb:**

1. Improper wiring?
2. Poor socket connections?

- 3. Voltage too low?
- 4. Defective bulbs?
- 5. Incorrect ballast?
- 6. Case too cold?
- D. Shorter Lamp Life:
  - 1. Incorrect wiring to lamp or ballast?
  - 2. Incorrect socket connection?
  - 3. Incorrect bulbs or ballast?
- E. Blinking Lamps:
  - 1. Voltage too high?
  - 2. Wrong bulbs or ballast?
  - 3. Incorrect socket wiring?
  - 4. Incorrect number of lamps for ballast?
- F. Ballast (Humm-Noise):
  - 1. Defective ballast?
  - 2. Loose can or cover?

**XXXIV. Safety Precautions**

- 1. Always turn off power to case, doors and frames before starting work.
- 2. Always use a qualified electrician for electrical work.
- 3. Always wear safety glasses when working on equipment.

**XXXV. Tips**

- 1. ***Never splice door or frame heater wire.*** Complete replacement recommended.
- 2. When installing gasket and plastics, use a liquid soap.
- 3. Keep doors and frames clean.
- 4. For binding gasket or plastic parts, use a food grade silicone.
- 5. Always replace lamp shields when lamps are replaced.
- 6. Preventive maintenance is the key to door and frame longevity.



## COMPANY POLICIES, TERMS OF SALE, AND WARRANTY

The following terms and conditions shall apply to all transactions and agreements between Anthony, Inc. ("Anthony") and the other party to such transaction or agreement ("Buyer") with respect to the purchase of any goods from Anthony and/or the extension of credit by Anthony to Buyer for such purchase.

- 1. PRICE.** Prices shown on the face of the sales invoice are F.O.B. the place of shipment as designated by Anthony, packaged for shipment and subject to change without notice.
- 2. TERMS OF CREDIT.** All credit terms are net 30 days from date of invoice. Any deductions from the net invoice amount must be approved by a representative of Anthony authorized to make such changes. If credit is extended to Buyer, Anthony reserves the right to revoke such credit if Buyer fails to make timely payment for any goods delivered. Anthony reserves the right to require payment or other assurances which it deems necessary prior to the shipment of any goods. If, in Anthony's opinion, exercised in Anthony's subjective, good faith judgment, the Buyer's financial condition has deteriorated or the risk of non-payment has otherwise increased. Credit is subject to approval upon receipt of completed credit application. Any goods shipped prior to credit approval shall be shipped C.O.D., "Cashiers Check", or pre-payment. A \$25.00 charge will be applied for each returned check. Goods may not be returned for credit unless prior authorization and an authorization number have been granted by Anthony. A 1 ½ % per month charge will be assessed on past due amounts.
- 3. SHIPMENT OF GOODS / RETURN OF GOODS.** Every effort will be made to ship the goods on the scheduled shipment date and to maintain production schedules consistent therewith provided however, Anthony shall not be liable for any claims or consequential damages arising from the failure to meet any scheduled shipping dates. If Buyer refuses shipment of any standard catalog products under an acknowledged order and those products are consistent with that order and are not delivered damaged or defective, then Buyer will be responsible for (i) return shipment of the products to Anthony in original shipping containers; (ii) return freight to Anthony prepaid by Buyer; and (iii) a restocking charge to be determined by Anthony of not less than twenty-five percent (25%) of the sales price. Buyer assumes the risk of any return shipment damage or loss, the cost of which will be assessed by Anthony and added to the restocking charge. No custom products or custom sizes of catalog items may be returned to Anthony for credit unless those products are not consistent with an acknowledged order or they are defective. If they are defective, Anthony reserves the right to cure the defect at the ship-to location. Costs for special packaging and/or handling requested by Buyer will be billed to Buyer. Shipping terms are specified on the face of Anthony's quotation and/or price list, as applicable. Unless otherwise specified by Buyer in writing, Anthony shall select the method of shipment and direct shipment of materials to the specified delivery address of Buyer. In the event of any general freight increase or any governmental ruling or regulation that results in increased freight costs, Anthony may, without any advance notice, invoice Buyer for such additional costs. Acceptance and rejections of glass sheets, assembled sealed glass units, and finished doors shall be in accordance with the defect criteria set forth in Industry Specification ASTM C1036-06 Standards, level Q3.
- 4. RISK OF LOSS.** Subject to security interests retained by Anthony until payment for the goods is received in full, the title to such goods and risk of loss or damages thereto pass to Buyer upon completion of loading of goods on carrier at Anthony's factory. Buyer will unload shipments promptly and Buyer will be liable for any additional charges such as demurrage, storage, and labor incurred by its failure to do so. Any claims by Buyer for damages to the goods incurred during shipping shall be made to the carrier.
- 5. WARRANTIES.** The products which Anthony manufacture and offer for sale are warranted to: (i) be free from defects in materials and workmanship; and (ii) perform in accordance with applicable refrigeration standards as of the date of manufacture for a period of 15 months from the date and place of shipment, provided that the installation and maintenance of such products have been performed strictly in accordance with Anthony's designated specifications (the "Warranty"). Anthony shall provide all necessary parts and labor at its cost to fulfill said Warranty. The extent of Anthony's liability under the Warranty is limited to the repair or replacement, at Anthony's option, of any non-conforming products without charge, at Anthony's San Fernando manufacturing plant. Additionally, for a period of 10 years from the shipment date, Anthony will replace sealed glass units that are part of an original Anthony-manufactured door if the seal breaks and internal condensation results. Anthony-manufactured LED lighting have a five (5) year component warranty and fifteen (15) month labor warranty. The anti-fog coating is only warranted for a period of fifteen (15) months from date of shipment. Anthony reserves the right to change its warranty provisions at its sole discretion at any time with or without prior notification of such change.

### No Warranty for Non-Standard Products.

A "Non-Standard Product" is any product that is different in any manner from any Anthony product that has been previously designed and manufactured by Anthony in accordance with its standard specifications. A Non-Standard Product also includes any standard Anthony product that has been specially designed or modified to meet a particular Buyer specification, or that contains any additional or substituted product, part, accessory, equipment, fixture, component or material, or that has been assembled, manufactured, produced, or installed by any method or process, which is different from Anthony's standard specifications for such product.

Anthony expressly disclaims and make no warranties, express or implied, as to the condition, design, utility, quality, adequacy, or capacity with respect to any standard or Non-Standard Product, including, without limitation, any warranty of merchantability or fitness of such product for a particular purpose or intended use, whether or not such product has been designated by Anthony as a Non-Standard Product.

Anthony products are covered by one or more of the following United States Patents: RE035392, 5301092, 5720540, 5879070, 5895111, 5910083, 5902034, 5959816, 6010227, 6298615, 6302036, 6302557, 6389993, 6343405, 5116274, 5244273, 5255473, 5333355, 5471372, 5645330, 6632100, 8637093, 6638088, 6773130, 6641419, 6490983, 8609832, 6066833, 5884361, D600529, 7603882, 7273299, 7674019, D404935, D395968, D612517, 5622414, 7731395 B2.

Anthony products are covered by one or more of the following Foreign Patents: Canada: 2233401, Mexico: 185899, 189644, 202491, 238593, 227313, 236090. Other United States and Foreign Patents Pending.

All Non-Standard Products, whether sold separately, or incorporated and/or attached to standard Anthony products, and all services relating to such products, are sold to and accepted by Buyer "as is" and "with all faults." Without limiting any other provision of this purchase order, Anthony shall have no liability to Buyer for any claim, loss, damage, consequential damages or expense associated with any Non-Standard Product and/or its use or operation, or any other equipment or property of Buyer caused by or alleged to be caused by any such product or its use or operation, whether directly, indirectly, incidentally or consequentially, or by any inadequacy thereof or deficiency or defect therein.

The foregoing exclusion of warranty cannot be modified or waived except as expressly set forth in a writing signed by an officer of Anthony authorized to make such modification or waiver.

**THE ABOVE WARRANTY IS GIVEN IN LIEU OF ALL OTHER WARRANTIES, EXPRESSED OR IMPLIED, INCLUDING ANY IMPLIED WARRANTIES OF MERCHANTABILITY OR FITNESS FOR A PARTICULAR PURPOSE. ANTHONY SHALL NOT BE RESPONSIBLE FOR INCIDENTAL OR CONSEQUENTIAL DAMAGES INCLUDING BUT NOT LIMITED TO INJURY TO PERSONS OR PROPERTY.**

- 6. ACCEPTANCE OF PRODUCTS BY BUYER/CLAIMS:** Upon delivery, shipments must be inspected for damage, loss or shortage prior to acceptance from the carrier. If damage or shortage exists with respect to any shipment and it is not concealed, Buyer shall secure a notation of such damage or shortage from the delivering agent on the freight bill or delivery receipt. If damage is concealed, Buyer must notify Anthony within five (5) days of its delivery and hold the merchandise for its inspection. Any claims for visible loss or damage should be filed by Buyer with Anthony in writing immediately upon receipt of the materials. All claims of Buyer that materials delivered do not conform to the accepted order shall be handled as claims for breach of warranty and Buyer shall be limited to those remedies available for breach of warranty.
- 7. CLAIMS BY BUYER.** Anthony shall thereupon be afforded a reasonable opportunity to inspect the goods. All claims not made in the time period and manner specified above shall be deemed waived. All actions, claims or defenses by Buyer shall be deemed waived unless commenced or asserted within six (6) months of receipt of the goods. No claims for visible, external damage or shortage will be allowed unless they are accompanied by an inspection report or signed delivery receipt noting such loss or damage signed by a representative of the carrier and forwarded to the Anthony Vice President, Marketing & Sales within 30 days of the invoice date.
- 8. CANCELLATION.** Orders may not be canceled after receipt by Anthony unless Anthony consents in writing to such cancellation. Cancellation will be granted only on terms indemnifying Anthony against any loss resulting from such action. At minimum, Buyer will be liable for all cost incurred on the order through the cancellation date.
- 9. CHANGES BY ANTHONY.** Anthony reserves the right to change design, colors and specifications of any goods without notice to Buyer.
- 10. DEFAULT.** If Buyer defaults or fails to pay on the purchase of any goods or if a petition in bankruptcy is filed by or against Buyer, Anthony, in addition to other remedies, may repossess any goods which were previously delivered and for which payment has not been received, and may refuse to make further shipment of goods. Buyer agrees to pay Anthony's attorneys' fees, costs and expenses incurred as a result of Buyers default or failure to pay, including but not limited to any collection or repossession expenses.
- 11. ENTIRE AGREEMENT AND AMENDMENT.** The terms specified herein constitute the entire agreement between Anthony and Buyer with respect to the sale and purchase of the goods and any extension of credit. If Anthony and Buyer agree to amend or modify any terms and conditions specified herein, such amendment or modification must be expressly stated on the face of the sales invoice or by a written agreement duly executed by an officer of Anthony and the Buyer. The terms specified herein shall control in the event of any variance between these terms and any terms contained in Buyer's purchase orders.
- 12. GOVERNING LAW.** This purchase order, any agreements between Anthony and Buyer and all other claims that arise between the parties, whether sounding in contract or tort, shall be governed by, construed and enforced in accordance with the laws of the State of California. By entering into this purchase order and any other agreement with Anthony, Buyer consents to the jurisdiction of the courts of the State of California to determine all claims between the parties, regardless of whether said claims are contract claims, tort claims, patent claims, trademark claims or copyright claims. Venue of any lawsuit (State or Federal) against Anthony must be filed in Los Angeles County, California. Service of process on Buyer may be made by registered mail addressed to the Buyer.
- 13. SEVERABILITY.** If any provision of the terms and conditions specified herein shall be deemed invalid or unenforceable, the remaining terms and conditions shall be construed as though such provision does not appear herein and shall be otherwise fully enforceable.
- 14. HEADINGS.** The section headings contained herein have been inserted for convenient reference and shall not be considered in any questions of interpretation or construction of any agreements between Anthony and Buyer.

99-18396-W001\_B (11/4/2010)